

COMPACT 8/10 N

Electric scissor lifts

The Haulotte® advantages

- Stowed height allows passage through standard doorways
- 32 in (0.81 m) width allows operation in the most congested areas
- 7 ft 10 in (2.38 m) outside turning radius ensures excellent manoeuvrability
- 5 in (12.5 cm) ground clearance allows for both inside and outside use
- Pot Hole protection and load limiter in cage ensures maximum safety
- Driveable at full height
- High operating autonomy
- Robust, reliable and easy to maintain design

STANDARD FEATURES

- Non marking tyres
- Folding guardrails (Compact 10N)
- 3 ft (0.92 m) platform extension
- 2° tilt alarm
- Load limiter in cage
- 2 drive speeds
- 2 wheel drive and steer (front)
- Free wheeling device
- 24 V - 4 x 6 V - batteries
- 30 amp battery charger
- Battery charge indicator
- Hourmeter
- Horn in cage
- Towing hooks / lifting eyes
- Emergency lowering system
- Safety harness anchor points

OPTIONS & ACCESSORIES

- Motion alarm
- 230 V socket in platform
- 59 in (1.5 m) extension from upper control box
- Working light
- Flashing light
- Motion alarm for movements and translation
- Centralised battery filling
- Biodegradable oil
- Overload device

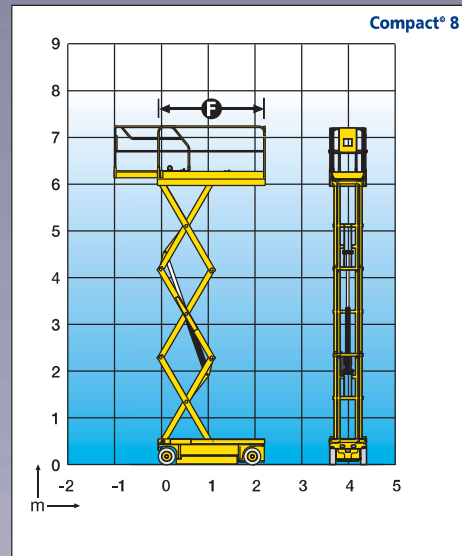
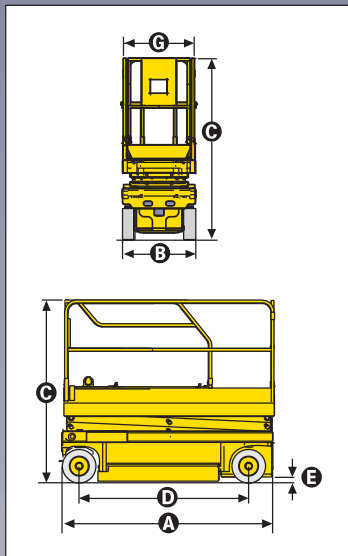

SPECIFICATIONS

	Compact 8		Compact 10 N	
Working height	26 ft 1 in	8.18 m	32 ft 10 in	10 m
Platform height	20 ft 3 in	6.18 m	26 ft 3 in	8 m
Driveable at full height	20 ft 3 in	6.18 m	26 ft 3 in	8 m
Platform capacity (total)	770 lb - 350 kg		500 lb - 230 kg	
A Stowed length	7 ft 7 in - 2.31 m			
with access steps	8 ft 2 in - 2.48 m			
B Width	32 in - 0.81 m			
C Stowed height	6 ft 6 in	1.99 m	7 ft 2 in	2.18 m
Transport height	2 ft 10 in	1.14 m	3 ft 6 in	1.33 m
D Wheelbase	6 ft 1 in - 1.86 m			
E Ground clearance	5 in - 12.5 cm			
with deployed Pot Hole	1 in - 2.5 cm			
F x G Platform size	7 ft 7 in X 2 ft 7 in - 2.3 m x 0.8 m			
Extension : Size	3 ft - 0.92 m			
Extension : Capacity	330 lb - 150 kg		260 lb - 120 kg	
Drive speed	0.6 - 2.2 mph - 1 km/h - 3.5 km/h			
Inside turning radius	13 in - 0.34 m			
Outside turning radius	7 ft 10 in - 2.38 m			
Lift / lower speed (sec.)	37 / 41 sec		51/42 sec.	
Gradeability	25%		23%	
Tilt Alarm	2°			
Controls	Proportional			
Batteries (amp/h)	180		180	
Tyres (solid / non marking)	15 x 5 x 2 in - 38 x 13 x 5 cm			
Hydraulic tank	6.6 gal - 27 l			
Weight	3.815 lb	1.730 kg	4.760 lb	2.160 kg

AS 1418.10



HAULOTTE UK LTD • STAFFORD PARK 6 • TELFORD - SHROPSHIRE TF3 3AT • TEL: +44 (0)1952 292753 • FAX: +44 (0)1952 292758 • E-mail: haulotte@haulotte.co.uk
 HAULOTTE SCANDINAVIA AB • ARÖDS INDUSTRIVÄG 66 B • 422 43 HISINGS BACKA - SWEDEN • TEL: +46 31 744 32 90 • FAX: +46 31 744 32 99 • E-mail: hwallin@haulotte.se • www.haulotte.se
 HAULOTTE AUSTRALIA PTY LTD • 65 LICOLA CRES • DANDENONG - VIC - 3175 • TEL: +61 (0)3 9706 6787 • FAX: +61 (0)3 9706 6797 • E-mail: sales@haulotte.com.au
 HAULOTTE SINGAPORE PTE. LTD • 26 Changi North Road Way • SINGAPORE 498812 • TEL: +65 6536 3989 • FAX: +65 6536 3969 • E-mail: haulotteasia@haulotte.com

Haulotte 
GROUP