

SYSTEM 36

FOR TELESCOPIC CRANE AND CRAWLER CRANE

- **SYSTEM 36 Automatic Safe Load Indicator** offers all the advantages of the microprocessor technique in combination with reliability and versatility
- High reliability by use of fewer circuit boards with full line of up-grade options available
- Minimum on-site installation time
- Housing protection class IP56
- Continuous self-check of central circuit and all sensors
- Compact design
- High accuracy

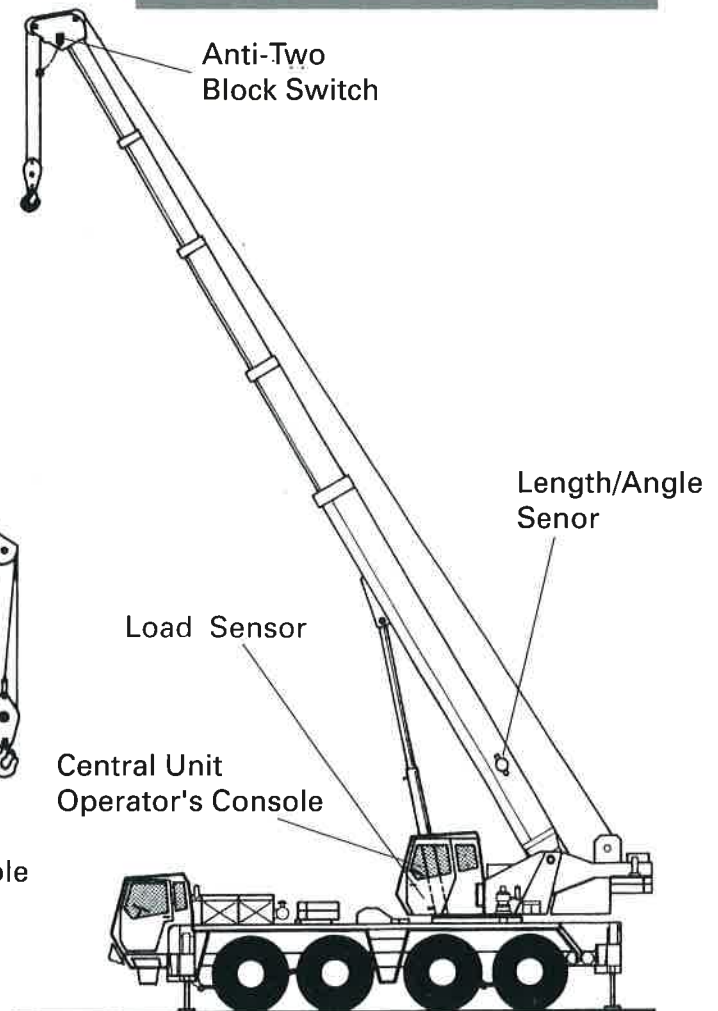
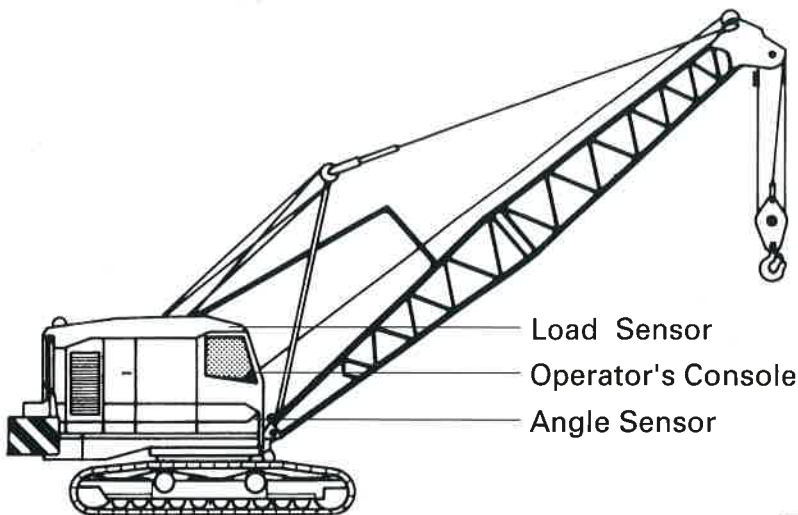
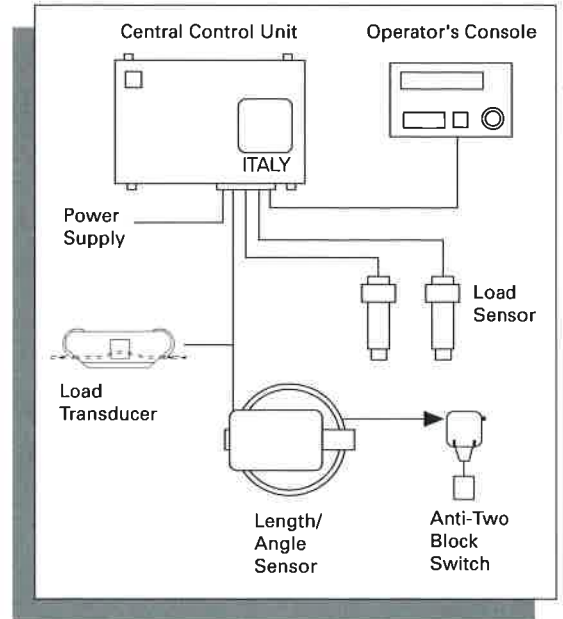

Sole Agent:



LINK ATTEMPT LTD.

A.S.L.I.

SYSTEM

SYSTEM 606

A.S.L.I. SYSTEM FOR EXCAVATOR AND TOW TRUCK

*Special design for excavator and tow truck
when it is used as lifting appliance*

- *Minimum ON-SITE installation time*
- *High Accuracy*
- *Compact and Reliable*
- *Protection up to IP56*
- *Individual audio and visual signals for
alarm and pre-alarm*

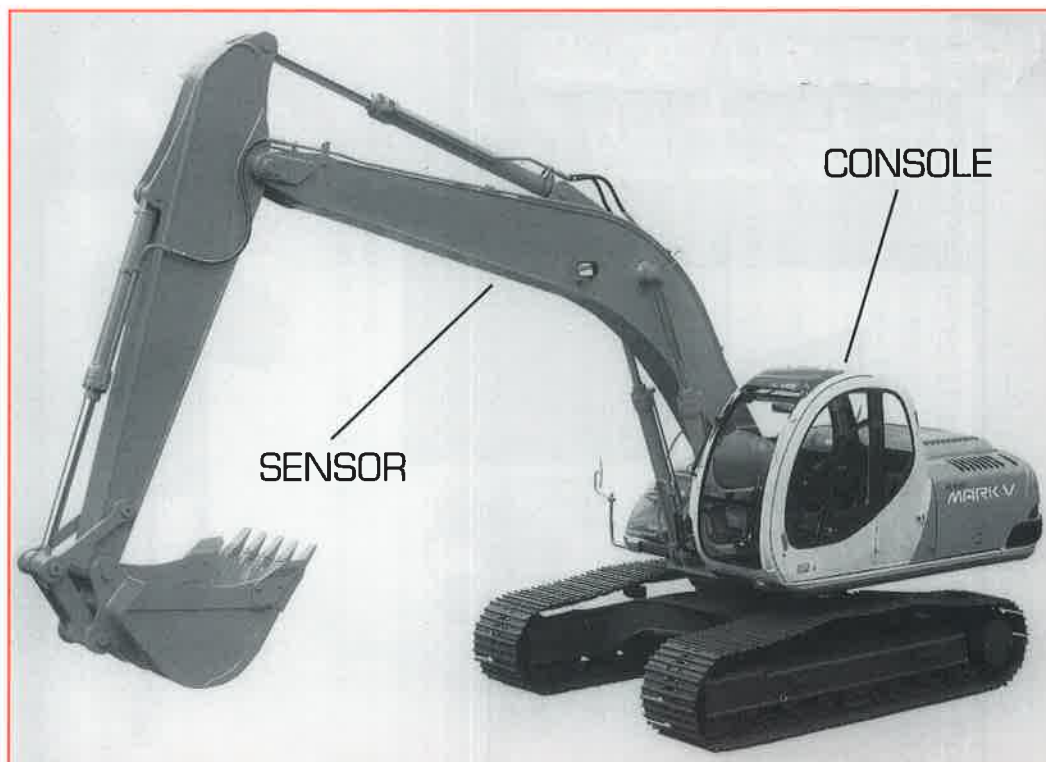
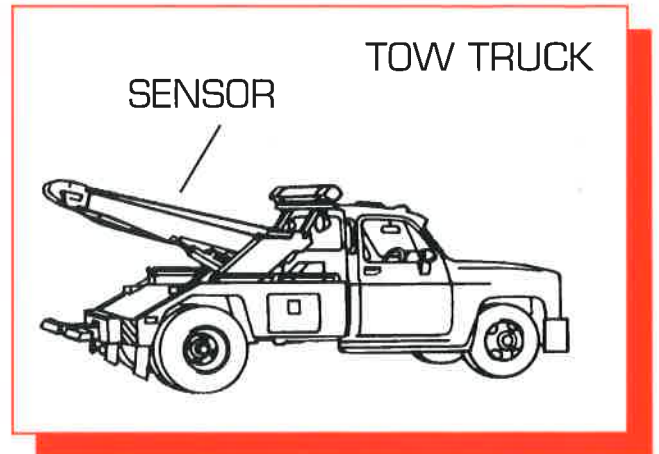

Sole Agent:

BAC
ITALY



LINK ATTEMPT LTD.

A.S.L.I.

SYSTEM

SYSTEM 602

**FOR AERIAL PLATFORM,
ACCESS PLATFORM,
GONDOLA AND HOIST.**

- *Minimum ON-SITE installation time*
- *Individual audio and visual signals for alarm and pre-alarm*
- *High Accuracy*
- *Compact and Reliable*
- *Protection up to IP56*

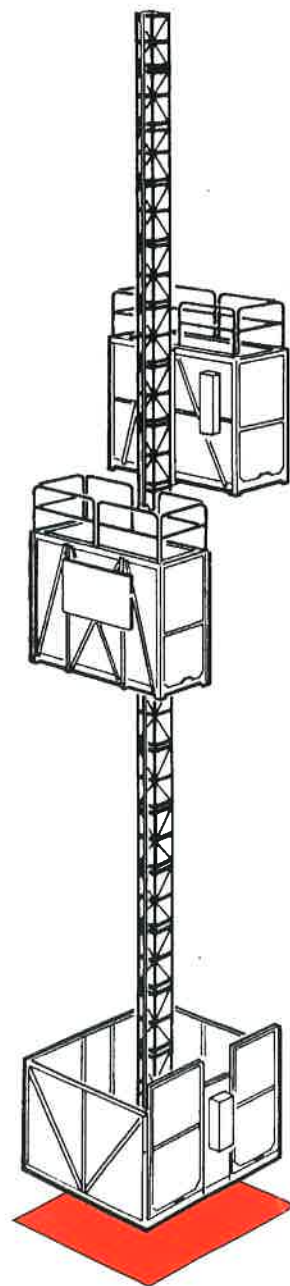
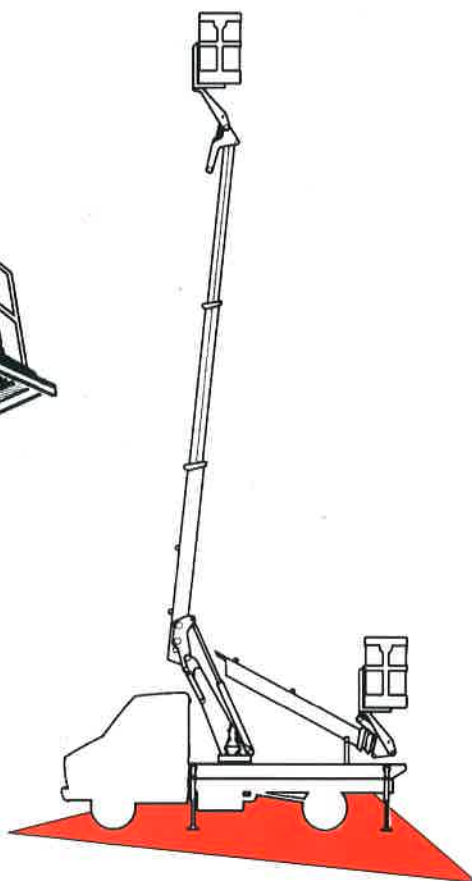
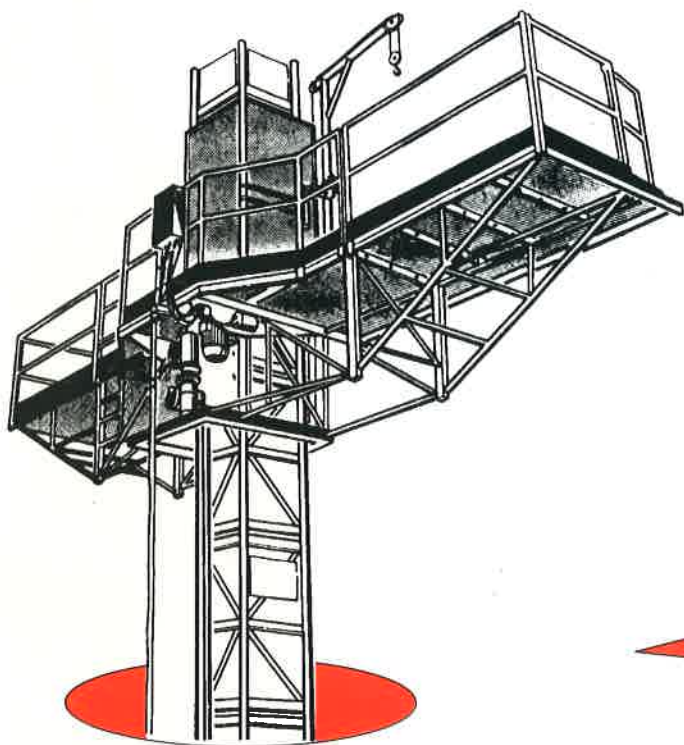

Sole Agent:

BAC
ITALY



LINK ATTEMPT LTD.